

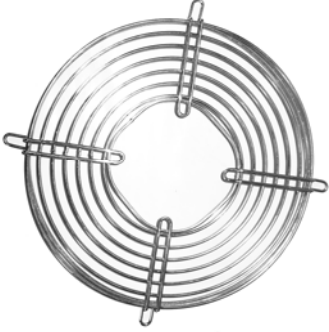



# ACCESSOIRES MOTEUR DE VENTILATION

| FG - Grille - Acier galvanisé. |    |     |    |    |     |         |           |  |
|--------------------------------|----|-----|----|----|-----|---------|-----------|--|
| TYPE                           | P  | Q   | S  | T  | R   | CODE    | P.u. HT € |  |
| FG-172                         | 14 | 208 | 11 | 45 | 56  | 170 038 | 4.19      |  |
| FG-200                         | 25 | 236 | 25 | 51 | 76  | 170 046 | 5.17      |  |
| FG-230                         | 32 | 266 | 27 | 57 | 84  | 170 054 | 5.97      |  |
| FG-254                         | 38 | 290 | 19 | 64 | 83  | 170 062 | 6.77      |  |
| FG-1300                        | 44 | 344 | 46 | 70 | 116 | 170 070 | 8.43      |  |

| FV - Virole - Acier galvanisé. |    |     |     |     |     |     |         |           |
|--------------------------------|----|-----|-----|-----|-----|-----|---------|-----------|
| TYPE                           | P  | D   | N   | F   | G   | Ø   | CODE    | P.u. HT € |
| FV-172                         | 14 | 182 | 208 | 233 | 97  | 172 | 170 151 | 5.05      |
| FV-200                         | 25 | 210 | 236 | 246 | 109 | 200 | 170 164 | 5.97      |
| FV-230                         | 32 | 240 | 266 | 276 | 115 | 230 | 170 178 | 6.77      |
| FV-254                         | 38 | 264 | 290 | 300 | 122 | 254 | 170 186 | 7.64      |
| FV-300                         | 44 | 310 | 344 | 356 | 128 | 300 | 170 194 | 9.29      |

| FE - Pied - Acier galvanisé. |     |    |     |    |    |         |           |
|------------------------------|-----|----|-----|----|----|---------|-----------|
| TYPE                         | H   | X  | Y   | C  | L  | CODE    | P.u. HT € |
| FE-54                        | 54  | 84 | 106 | -  | 24 | 170 275 | 1.55      |
| FE-72                        | 72  | 84 | 106 | -  | 24 | 170 283 | 2.02      |
| FE-81                        | 81  | 84 | 106 | -  | 24 | 170 291 | 2.02      |
| FE-109                       | 109 | 84 | 106 | 21 | 39 | 170 305 | 2.87      |

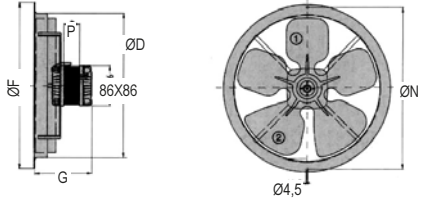